

NEUTRONE®

BG SERIES
END SUCTION CENTRIFUGAL PUMP

ISO 2858

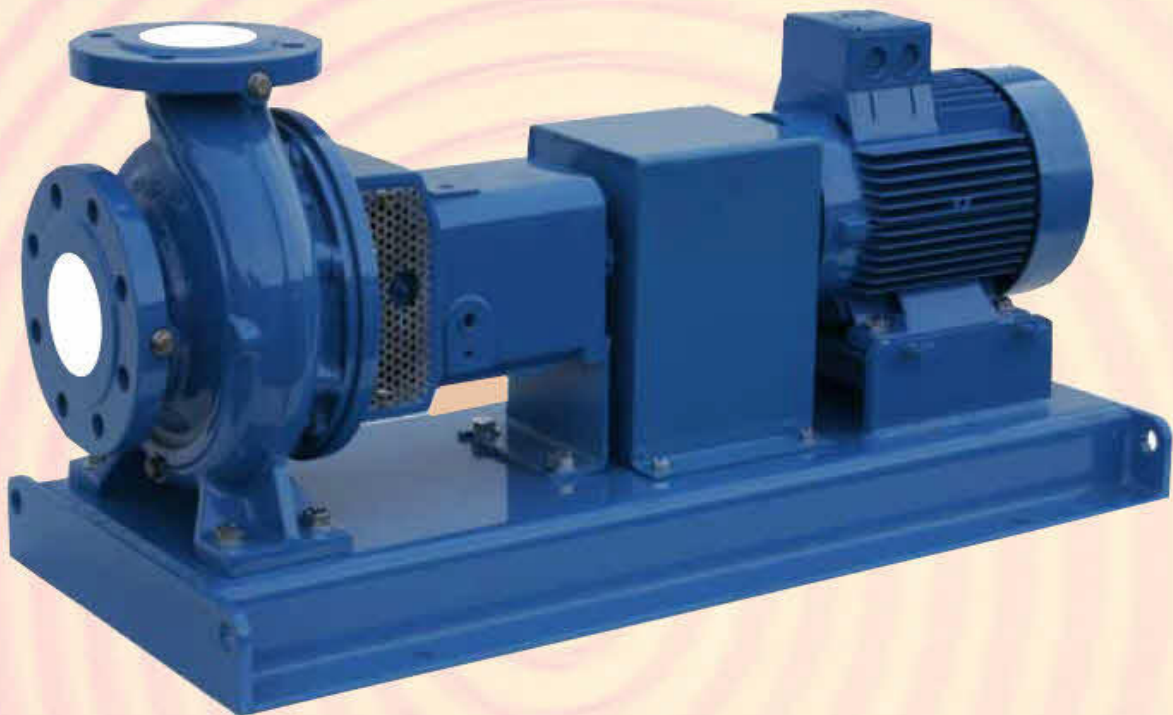

APPLICATIONS

- * Air Conditioning
- * Fire Protection
- * Circulating
- * Irrigation
- * Pressure Boosting
- * Water Treatment & Supply
- * Plumbing
- * Liquid Transfer
- * Drainage
- * De-watering
- * Cooling Towers
- * Refrigeration

NEUTRONE®

BG SERIES END SUCTION CENTRIFUGAL PUMP

The BG range has been designed to international standard ISO2858 ensuring a sturdy & reliable, long lasting, high performing product.

Applications

Water Supply

Commercial irrigation, booster stations, municipal water supply, flood irrigation, general transfer.

Industry

Cooling tower transfer, refrigeration systems, commercial fountains, condensate recovery, dairy wash down packages.

Environmental

Dust suppression in mining & quarry applications, fume scrubbers for odour control, water treatment transfer & filtration.

Leisure

Circulation in large aquatic centres, backwash filtration in commercial pools, water features & commercial fountains.

Building Services

Commercial heating, air conditioning systems, pressure boosting, cooling tower & fire fighting applications.

Pumped Liquids

Non aggressive & non combustible liquids. Clean low viscous liquids free of fibres or particles.

Operating Conditions

BG Series Bareshaft Pumps

Maximum flow _____ 900 m³/hr
Maximum total heads _____ 160 m
Liquid temperature* _____ -15 to 140°C
Operating pressure _____ 16 Bar

* With optional high temperature seal.

Design Features

Bronze wear rings - fitted as standard, replaceable front & rear wear rings with optional materials, for a trouble free lifecycle.

Impeller - cast iron closed design is fitted as standard to prevent corrosion in stationary. Cast SS304 or SS316 are available on request. Impeller diameters can be trimmed to specified performance. BG series impellers are dynamically balanced, vibration free operation, preventing premature bearing failure.

Pump casing - highly efficient cast iron volute casings, with flanges rated to PN16.

Casing o-ring - re-usable o-rings in Nitrile for ease of re-assembly (optional materials available).

Shaft seal - single, high quality or approved equivalent mechanical seal with carbon vs ceramic fitted as standard to all BG series pumps with other options such as silicone vs silicone or high temperature also available.

Tappings - convenient suction & discharge pressure gauge tappings plus volute drain, fitted as standard.

Model Designation (Examples)

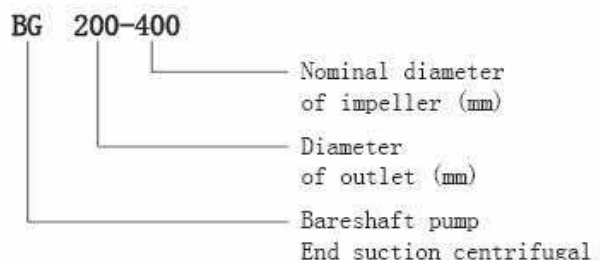

NEUTRONE®

BG SERIES

END SUCTION CENTRIFUGAL PUMP

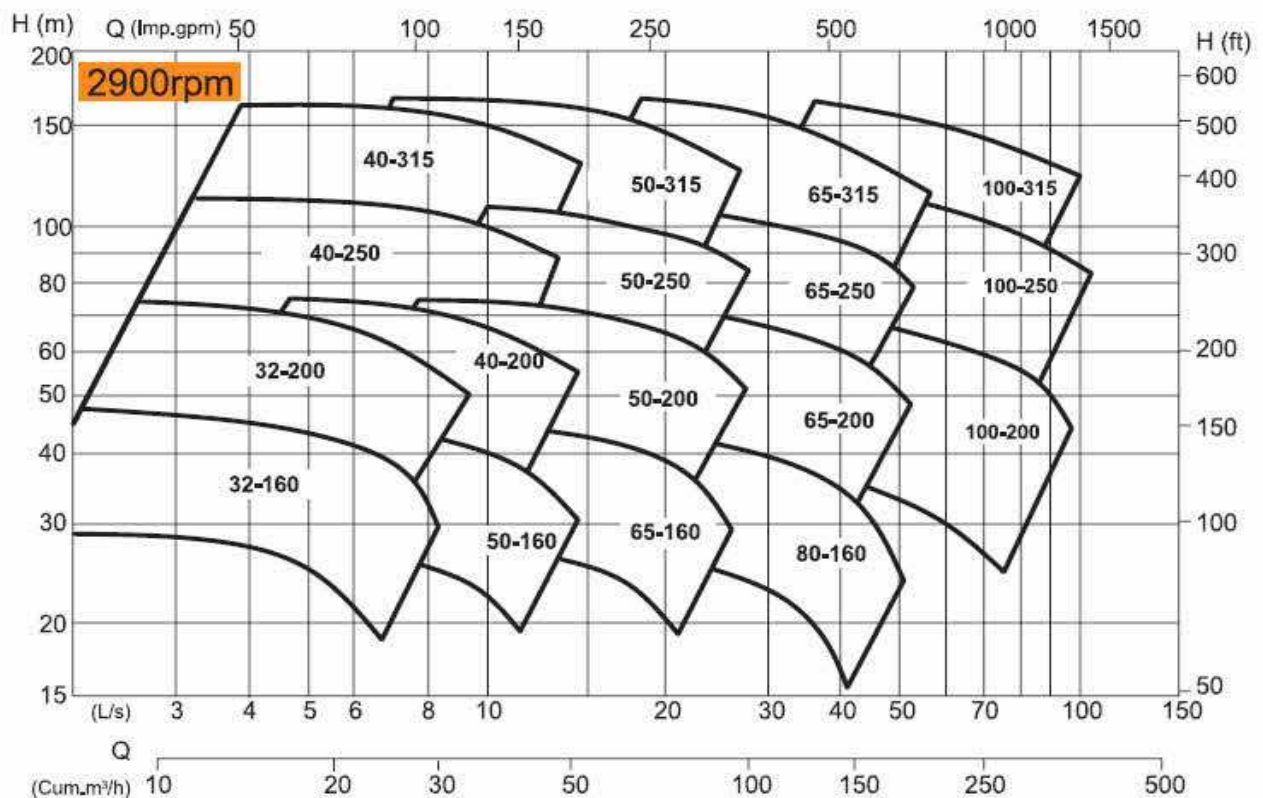
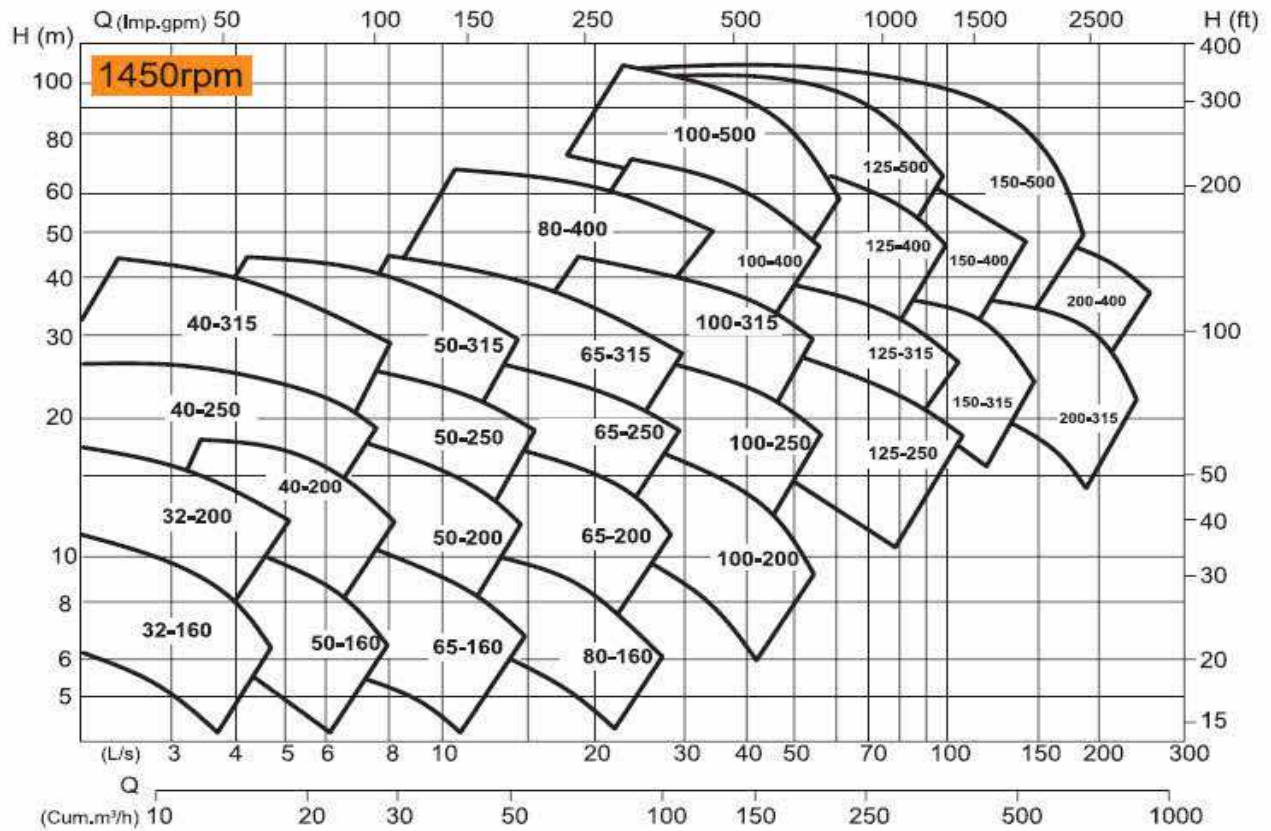

BG SERIES

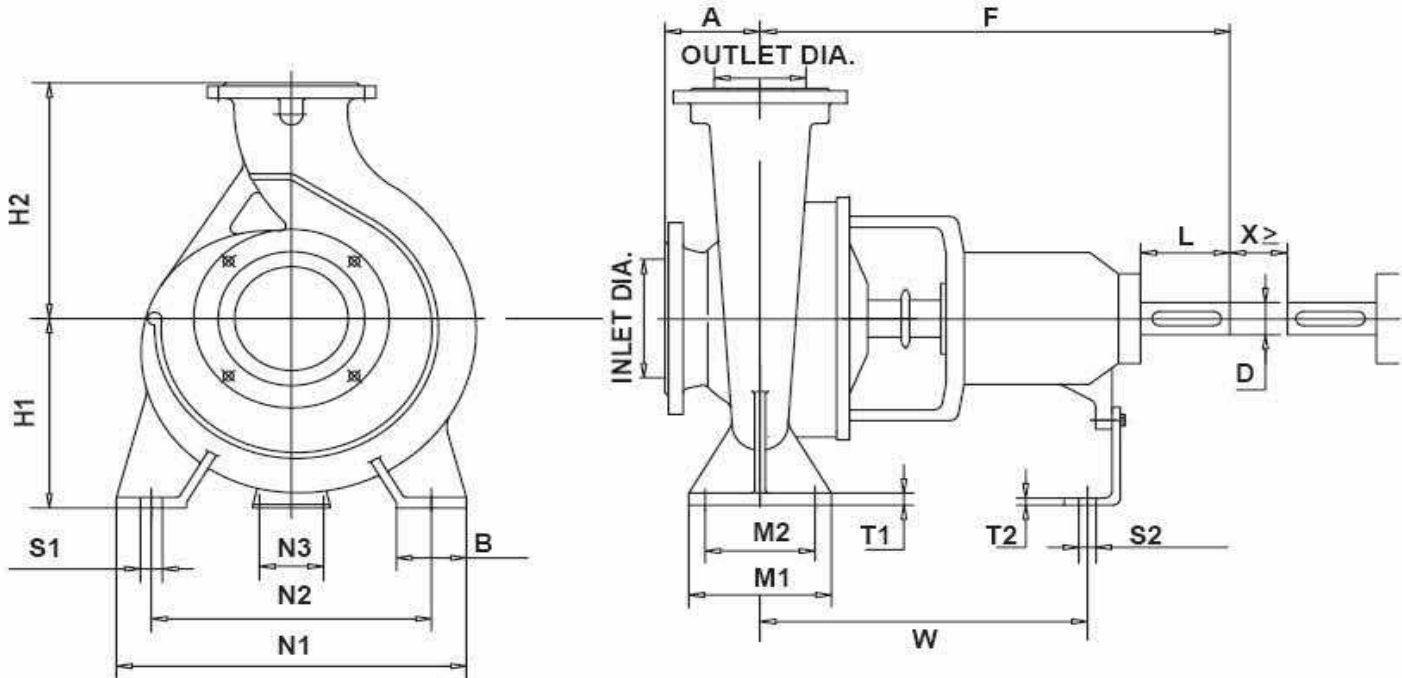

Pump Model	Pump End			Shaft No	Pump dimensions				Mounting Dimensions								Bolt Holes		Shaft End	Gap	Wt kg		
	In	Out	Imp		A	F	H1	H2	B	M1	M2	N1	N2	N3	T1	T2	W	S1				S2	D
32-160	50	32	160	1	80	385	132	160	50	100	70	240	190	110	12	6	285	M12	M12	24	50	100	38
32-200	50	32	200	1	80	385	160	180	50	100	70	240	190	110	12	6	285	M12	M12	24	50	100	46
50-160	65	50	160	1	80	385	132	160	50	100	70	240	190	110	12	6	285	M12	M12	24	50	100	40
40-200	65	40	200	1	100	385	160	180	50	100	70	265	212	110	13	6	285	M12	M12	24	50	100	48
40-250	65	40	250	2	100	500	180	225	65	125	95	320	250	110	14	6	370	M12	M12	32	80	100	70
40-315	65	40	315	2	125	500	200	250	65	125	95	345	280	110	16	6	370	M12	M12	32	80	100	80
65-160	80	65	160	1	100	385	160	180	50	100	70	265	212	110	13	6	285	M12	M12	24	50	100	46
50-200	80	50	200	1	100	385	160	200	50	100	70	265	212	110	13	6	285	M12	M12	24	50	100	52
50-250	80	50	250	2	125	500	180	225	65	125	95	320	250	110	15	6	370	M12	M12	32	80	100	72
50-315	80	50	315	2	125	500	225	280	65	125	95	345	280	110	18	6	370	M12	M12	32	80	100	87
80-160	100	80	160	2	100	500	160	200	65	125	95	280	212	110	14	6	370	M12	M12	32	80	100	68
65-200	100	65	200	2	100	500	180	225	65	125	95	320	250	110	14	6	370	M12	M12	32	80	140	70
65-250	100	65	250	2	125	500	200	250	80	160	120	360	280	110	16	6	370	M16	M12	32	80	140	80
65-315	100	65	315	3	125	530	225	280	80	160	120	400	315	110	18	6	370	M16	M12	42	110	140	118
80-400	125	80	400	3	125	530	280	355	80	160	120	435	355	110	20	6	370	M16	M12	42	110	140	165
100-200	125	100	200	2	125	500	200	280	80	160	120	360	280	110	17	6	370	M16	M12	32	80	140	85
100-250	125	100	250	3	140	530	225	280	80	160	120	400	315	110	18	6	370	M16	M12	42	110	140	126
100-315	125	100	315	3	140	530	250	315	80	160	120	400	315	110	19	6	370	M16	M12	42	110	140	135
100-400	125	100	400	3	140	530	280	355	100	200	150	500	400	110	20	6	370	M20	M12	42	110	140	175
100-500	125	100	500	4	160	670	355	450	100	200	150	550	450	110	25	10	500	M20	M16	48	110	180	313
125-250	150	125	250	3	140	530	250	355	80	160	120	400	315	110	19	6	370	M16	M12	42	110	140	140
125-315	150	125	315	3	140	530	280	355	100	200	150	500	400	110	20	6	370	M20	M12	42	110	140	150
125-400	150	125	400	3	140	530	315	400	100	200	150	500	400	110	21	6	370	M20	M12	42	110	140	186
125-500	150	125	500	4	160	670	355	450	100	200	150	550	450	140	25	10	500	M20	M16	48	110	180	336
150-315	200	150	315	4	160	670	315	400	100	200	150	550	450	140	25	10	500	M20	M16	48	110	180	222
150-400	200	150	400	4	160	670	315	450	100	200	150	550	450	140	25	10	500	M20	M16	48	110	180	300
150-500	200	150	500	4	160	670	400	500	100	200	150	550	450	140	25	10	500	M20	M16	48	110	180	382
200-315	250	200	315	4	180	670	315	450	100	200	150	550	450	140	25	10	500	M20	M16	48	110	180	277
200-400	250	200	400	4	180	670	355	500	100	200	150	550	450	140	25	10	500	M20	M16	48	110	180	340